

ROZMERY





VÝŠKA x ŠÍŘKA x HLOUBKA	570x753x494 mm
HMOTNOST BRUTTO/NETTO	131/105 kg
PŘÍKLÁDACÍ OTVOR	550x300 mm
PRŮMĚR KOUŘOVODU VÝVOD KOUŘOVODU	Ø 150-153 mm Vrchní
EXTERNÍ PŘÍVOD VZDUCHU	Ø 80 mm

CHARAKTERISTIKA

ŽELEZNÝ ROŠT	
OCELOVÝ PLÁŠŤ KAMEN	3 mm
JMENOVITÝ VÝKON	7 KW
ÚČINNOST SPALOVÁNÍ	81 %
EMISE CO	0,10%
ŽÁRUVZDORNÁ BARVA	800°C
KERAMIZOVANÉ ŽÁRUVZDORNÉ SKLO	750°C

VLASTNOSTI

ECODESIGN

-  **EXTERNÍ PŘÍVOD VZDUCHU**
-  **BÍLA ŽÁRUVZDORNÁ VYZDÍVKA**
-  **POTIŠTĚNÉ SKLO**
-  **MAXIMÁLNÍ DÉLKA POLEN 50 CM**
-  **210 m³** VYTÁPĚCÍ SCHOPNOST
-  **SYSTÉM ČISTÉHO SKLA**
-  **TERCIÁRNÍ SPALOVÁNÍ**
-  **KANALIZACE VZDUCHU**
-  **TANGENCIÁLNÍ VENTILÁTOR**

C-700

EcoDesign

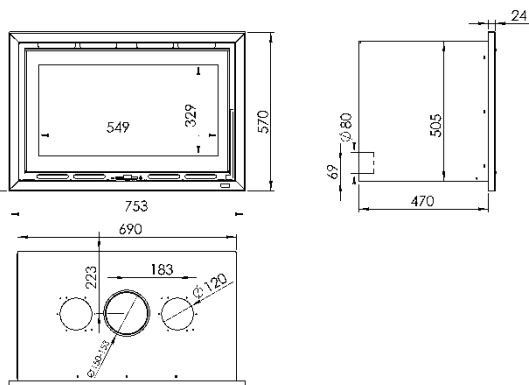

EAN 8426964248050
REF. 24805



BlmSchV2

