

## MEDIDAS E PESOS

DIMENSÕES A x L x P	793x500x546 mm
PESO BRUTO/LÍQUIDO	125/102 kg
MEDIDAS DA PORTA	432x337 mm
SAÍDA DE FUMOS	Ø 150-153 mm Vertical
ADMISSÃO DE AR DO EXTERIOR	Ø 80 mm

## CARACTERÍSTICAS TÉCNICAS

GRADE DE CINZAS EM FERRO FUNDIDO	
TRIVISÃO	
CORPO EM AÇO	5 mm
POTÊNCIA NOMINAL	8 KW
RENDIMENTO	78,5 %
EMIÇÃO DE CO	0,10 %
PINTURA RESISTENTE A ALTA TEMPERATURA	800°C
VIDRO VITROCERÂMICO RESISTENTE A	750°C

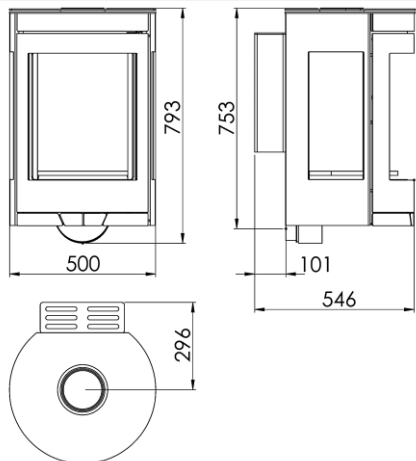

## PRODUTO PLUS

### ECODESIGN



ADMISSÃO DE AR DO EXTERIOR



CÂMARA DE COMBUSTÃO REVESTIDA EM VERMICULITE



TRONCOS DA LENHA ATÉ 50 CM



240 m<sup>3</sup> VOLUME DE AQUECIMENTO



SISTEMA VIDRO LIMPO



TRIPLA COMBUSTÃO



FECHO DUPLO



A

EAN 8426964241051  
REF. 24105



BlmSchV2



# LINZ WALL EcoDesign



LINZ WALL PT