

MÉRETEK

MÉRET (M x SZ x Mé)	793x500x546 mm
BRUTTÓ/NETTÓ SÚLY	125/102 kg
AJTÓ MÉRETE	432x337 mm
FÜSTCSŐCSONK ÁTMÉRŐ	Ø 150-153 mm Függőleges
TERMÉSZETES KÖBURKOLAT	Ø 80 mm

TULAJDONSÁGOK

ÖNTÖTTVAS RÁCS	
ACÉL TEST	5 mm
NÉVLEGES TELJESÍTMÉNY	8 KW
HATÁSFOK	78,5 %
CO KIBOCSÁJTÁS	0,10 %
HŐÁLLÓ FESTÉK	800°C
ELLENÁLLÓ KERÁMIA ÜVEG	750°C

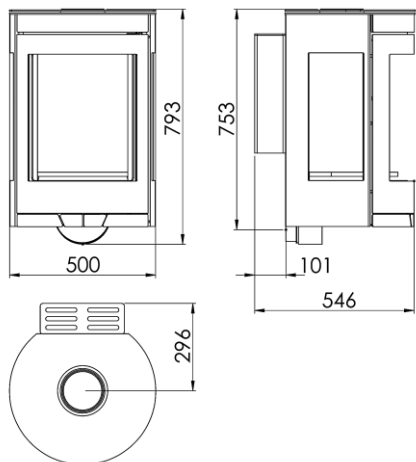

PLUSZ TERMÉK

ECODESIGN



KÜLSŐ LEVEGŐ
BEVEZETÉS



VERMIKULIT BELSŐ



ÜZIFA MÉRET 50 CM



240
m³ TRIPLA ÉGÉS



TISZTA ÜVEG RENDSZER



3 TRIPLA ÉGÉS



KETTŐS ZÁR



A

EAN 8426964241051
REF. 24105



LINZ WALL HU

LINZ WALL EcoDesign



BlmSchV2

