

## MEDIDAS

DIMENSIONES A x A x F	795x500x540 mm
PESO BRUTO/NETO	118/109 kg
DIMENSIONES PUERTA	432x337 mm
SALIDA DE HUMOS	Ø 150-153 mm Vertical
ENTRADA DE AIRE EXTERIOR	Ø 80 mm

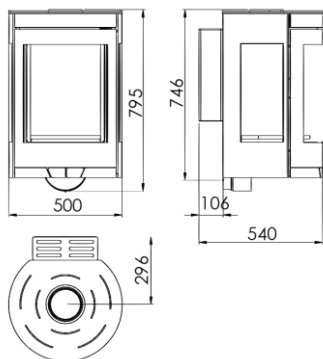



## CARACTERÍSTICAS

PARRILLA DE HIERRO FUNDIDO	
TRIVISION	
VIDRIO VITRIFICADO EN PARTE SUP.	
CUERPO EN CHAPA	5 mm
POTENCIA CALORÍFICA	8 KW
RENDIMIENTO	78,5 %
EMISIÓN DE CO	0,10 %
PINTURA ANTI-CALÓRICA RESISTENTE	800°C
CRISTAL VITROCERÁMICO RESISTENCIA	750°C



## PLUS PRODUCTO

### ECODESIGN

-  TOMA DE AIRE EXTERIOR
-  REFRACTARIO
-  TRONCOS HASTA 50 CM
-  240 m<sup>3</sup> VOLUMEN CALEFACCIÓN
-  SISTEMA CRISTAL LIMPIO
-  TRIPLE COMBUSTION
-  DOBLE CIERRE



EAN 8426964241051  
REF. 24105



LINZ WALL ES

# LINZ WALL EcoDesign



BlmSchV2

