

## WYMIARY









WYS.xSZER.xGŁ.	627x1120x470mm
WAGA BRUTTO/NETTO	135/122 kg
WYMIARY DRZWICZEK	885x300 mm
WYLOT SPALIN	Ø 150-153 mm Pionowy
DOLOT POWIETRZA Z ZEWNĄTRZ	Ø 80 mm

## CHARAKTERYSTYKA

RUSZT ŻELIWNY	
KORPUS ZE STALI	3 mm
MOC NOMINALNA	8,9 KW
SPRAWNOŚĆ	80,8 %
EMISJA CO	0,10 %
FARBA ŻAROODPORNĄ	800°C
SZYBA SZKLANO-CERAMICZNA	750°C

## ZALETY PRODUKTU

### ECODESIGN 2022

-  **DOLOT POWIETRZA Z ZEWNĄTRZ**
-  WNIĘTRZE WYŁOŻONE WERMIKULITEM
-  DŁUGOŚĆ POLAN DO 80 CM
-  OGRZEWANA KUBATURA
-  SPALANIE DWUSTOPNIOWE
-  SYSTEM CZYSTA SZYBA
-  SZYBA Z SITODRUKIEM
-  WENTYLATOR STYCZNY
-  SYSTEM DGP



EAN 8426964249019  
REF. 24901



# DC-100 EcoDesign

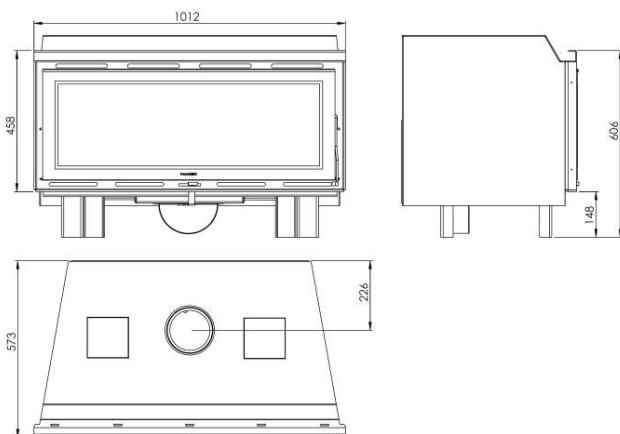

BImSchV2

