

# DENIA®

S T O V E S







## MAßE

MAßE H x B x T	627x1120x570mm
GEWICHT BRUTTO/NETTO	135/122 kg
MAßE FEUERRAUMTÜR	885x300 mm
DURCHMESSER DES ABGASSTUTZEN	Ø 150-153 mm Vertical
EXTERNE LUFTZUFUHR	Ø 80 mm

## EIGENSCHAFTEN

RÜTTELROST AUS GUSSEISEN	
BLECHGEHÄUSE	3 mm
NENNLEISTUNG	8,9 KW
WIRKUNGSGRAD	80,8 %
CO - EMISSIONEN	0,10 %
HITZESCHUTZANSTRICH	800°C
GLASKERAMIKSCHEIBE HITZEBESTÄNDIG BIS	750°C

## PRODUKT PLUS ECODESIGN 2022

-  EXTERNE LUFTZUFUHR
-  VERMIKULIT AUSKLEIDUNG
-  BEDRUCKTE GLASKERAMIK
-  SCHEITLÄNGE 80 CM
-  240 m³ RAUMHEIZVERMÖGEN
-  SCHEIBENSPÜLUNG
-  DREIFACHVERBRENNUNG
-  TANGENTIELLER VENTILATOR
-  WARMLUFT KANALISATION

# DC-100 EcoDesign

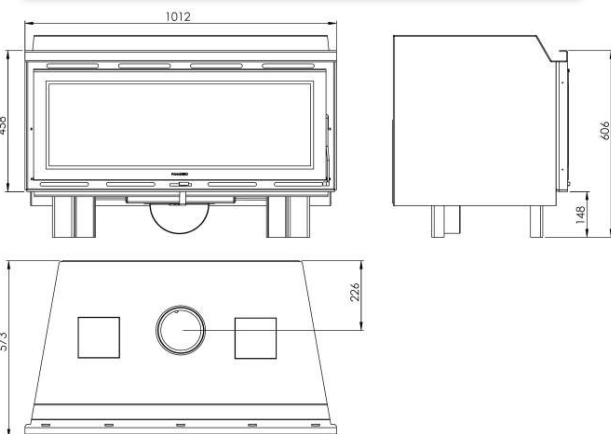

EAN 8426964249019  
REF. 24901



BImSchV2

