

## MISURE

DIMENSIONI A x A x P	<b>625x700x485 mm</b>
PESO LORDO/NETTO	<b>85/75 kg</b>
DIMENSIONI PORTA	<b>550x311 mm</b>
DIAMETRO SCARICO FUMI	<b>Ø 150-153 mm</b> Verticale
PRESA D'ARIA ESTERNA	<b>Ø 80 mm</b>

## CARATTERISTICHE

GRIGLIA IN GHISA	
VISTA PANORAMICA	
CORPO IN ACCIAIO DI	<b>3 mm</b>
POTENZA	<b>6.7 KW</b>
RENDIMENTO	<b>86 %</b>
EMISSIONI DI CO	<b>0,05%</b>
VERNICE ANTICALORE RESISTENTE A	<b>800°C</b>
CRISTALLO IN VITROCERAMICA RESISTENTE A	<b>750°C</b>

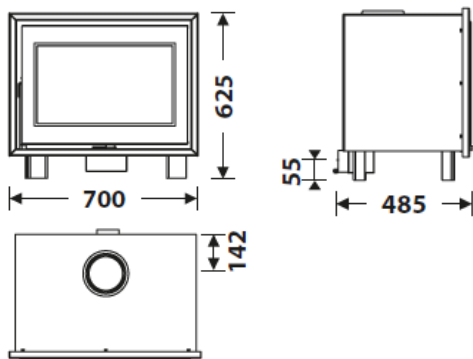

## PLUS PRODOTTO

### ECODESIGN

-  TRIPLA COMBUSTIONE
-  FOCOLARE RIVESTITO IN VERMICULITE
-  PORTA IN VETRO SERIGRAFATO
-  TRONCHI DI 50 CM
-  VOLUME DI RISCALDAMENTO **200 m³**
-  VETRO SEMPRE PULITO



**A+**



EAN 8426964347005  
REF. 34700



# DF-70 EcoDesign



DF-70 IT

