

MISURE

DIMENSIONI A x A x P	625x700x566 mm
PESO LORDO/NETTO	95/85 kg
DIMENSIONI PORTA	500x311 mm
DIAMETRO SCARICO FUMI	Ø 150-153 mm Verticale
PRESA D'ARIA ESTERNA	Ø 80 mm

CARATTERISTICHE

GRIGLIA IN GHISA	
VISTA PANORAMICA	
CORPO IN ACCIAIO DI	3 mm
POTENZA	7 KW
RENDIMENTO	81 %
EMISSIONI DI CO	0,10%
VERNICE ANTICALORE RESISTENTE A	800°C
CRISTALLO IN VITROCERAMICA RESISTENTE A	750°C

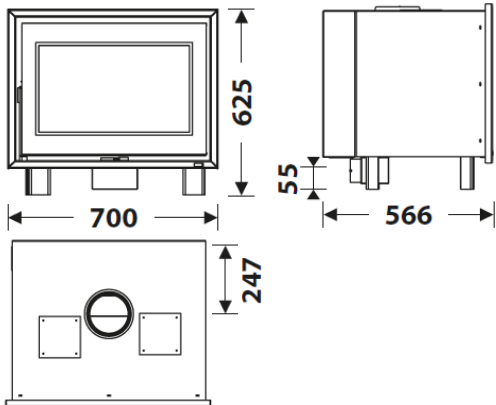

PLUS PRODOTTO

ECODESIGN

-  PRESA D'ARIA ESTERNA
-  FOCOLARE RIVESTITO IN VERMICULITE
-  PORTA IN VETRO SERIGRAFATO
-  TRONCHI DI 50 CM
-  **220 m³** VOLUME DI RISCALDAMENTO
-  VETRO SEMPRE PULITO
-  TRIPLA COMBUSTIONE
-  VENTILATORE TANGENZIALE
-  CANALIZZAZIONE D'ARIA CALDA



EAN 8426964248005
REF. 24800



DC-70 EcoDesign



DC-70 IT



BlmSchV2

