

MISURE

DIMENSIONI A x A x P	625x700x566 mm
PESO LORDO/NETTO	95/85 kg
DIMENSIONI PORTA	500x311 mm
DIAMETRO SCARICO FUMI	Ø 150-153 mm Verticale
PRESA D'ARIA ESTERNA	Ø 80 mm

CARATTERISTICHE

GRIGLIA IN GHISA	
VISTA PANORAMICA	
CORPO IN ACCIAIO DI	3 mm
POTENZA	6.7 KW
RENDIMENTO	86 %
EMISSIONI DI CO	0,05%
VERNICE ANTICALORE RESISTENTE A	800°C
CRISTALLO IN VITROCERAMICA RESISTENTE A	750°C

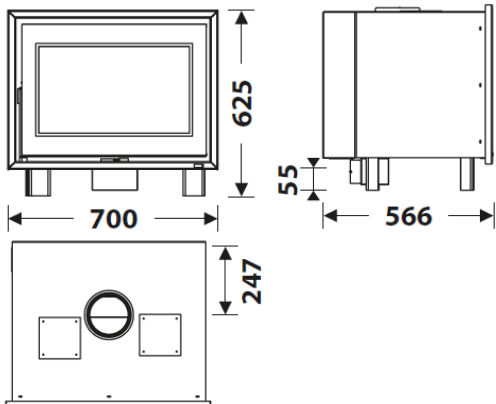

PLUS PRODOTTO

ECODESIGN

- FOCOLARE RIVESTITO IN VERMICULITE
- PORTA IN VETRO SERIGRAFATO
- TRONCHI DI 50 CM
- VOLUME DI RISCALDAMENTO **200 m³**
- VETRO SEMPRE PULITO
- TRIPLA COMBUSTIONE

DC-70 EcoDesign



DC-70 IT



A+



EAN 8426964348002
REF. 34800

