

DENIA®

S T O V E S

MEDIÇÕES E PESOS

DIMENSÕES A x L x P	1038x556x500 mm
PESO BRUTO/LÍQUIDO	180/170 kg
OCO ENTRADA LENHA	310x565 mm
SÁIDA DE FUMOS	Ø 150-153 mm Vertical
ENTRADA DE AIRE EXTERIOR	Ø 80 mm

CARACTERÍSTICAS TÉCNICAS

GRADE DE CINZAS EM FERRO FUNDIDO	
VISÃO PANORÂMICA	
CORPO EM AÇO	5+2,5 mm
POTÊNCIA NOMINAL	8 KW
RENDIMENTO	81 %
EMISSÃO DE CO	0,10 %
PINTURA RESISTENTE A ALTA TEMPERATURA	800°C
VIDRO CERÂMICO	750°C

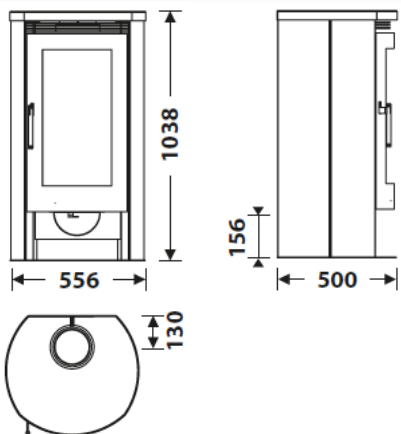

PLUS PRODUTO ECODESIGN 2022

-  ENTRADA DE AR EXTERNA
-  CÂMARA REVESTIDA EM VERMICULITE
-  TRONCOS DA LENHA ATÉ 50 CM
-  VOLUME DE AQUECIMENTO 250 m³
-  SISTEMA VIDRO LIMPO
-  CORPO DUPLO EM AÇO DE 5 + 2,5 mm
-  FECHO DUPLO
-  DUPLA COMBUSTÃO
-  LENHEIRO
-  PEDRA NATURAL



EAN 8426964242003
REF. 24200



BImSchV2



LAMBDA SOAP EcoDesign



LAMBDA SOAP

