

MEDIÇÕES E PESOS

DIMENSÕES A x L x P	879x857x469 mm
PESO BRUTO/LÍQUIDO	210/195 kg
OCO ENTRADA LENHA	620x286 mm
SÁIDA DE FUMOS	Ø 150-153 mm Vertical
ENTRADA DE AR EXTERNA	Ø 80 mm

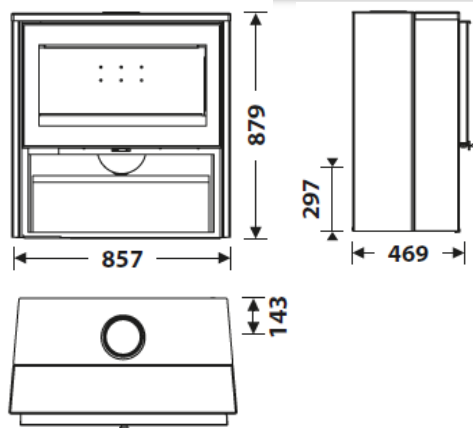









CARACTERÍSTICAS TÉCNICAS

GRADE DE CINZAS EM FERRO FUNDIDO	
VISÃO PANORÂMICA	
CORPO EM AÇO	5+3 mm
POTÊNCIA NOMINAL	7,2 KW
RENDIMENTO	78,9 %
EMISSÃO DE CO	0,10%
PINTURA RESISTENTE A ALTA TEMPERATURA	800°C
VIDRO CERÂMICO	750°C



PLUS PRODUTO

ECODESIGN 2022

-  ENTRADA DE AR EXTERNA
-  REFRAATÁRIO
-  TRONCOS DA LENHA ATÉ 60 CM
-  VOLUME DE AQUECIMENTO 250 m³
-  SISTEMA VIDRO LIMPO
-  PORTA COM VIDRO SERIGRAFADO
-  FECHO DUPLO
-  TRIPLA COMBUSTÃO
-  LENHEIRO
-  PEDRA NATURAL



EAN 8426964243000
REF. 24300



BImSchV2



FIREX EcoDesign

