

MEDIÇÕES E PESOS

DIMENSÕES A x L x P	625x770x485 mm
PESO BRUTO/LÍQUIDO	96/86 kg
OCO ENTRADA LENHA	600x300 mm
SAÍDA DE FUMOS	Ø 150-153 mm Vertical
ENTRADA DE AR EXTERNA	Ø 80 mm

CARACTERÍSTICAS TÉCNICAS

GRADE DE CINZAS EM FERRO FUNDIDO	
VISÃO PANORÂMICA	
CORPO EM AÇO	3 mm
POTÊNCIA NOMINAL	7 KW
RENDIMENTO	81 %
EMIÇÃO DE CO	0,10%
PINTURA RESISTENTE A ALTA TEMPERATURA	800°C
VIDRO CERÂMICO	750°C

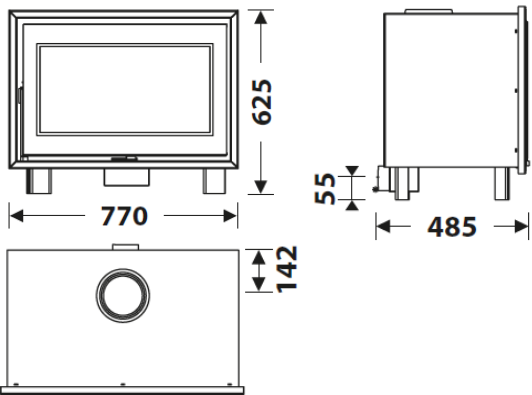

PLUS PRODUTO

ECODESIGN 2022

- ENTRADA DE AR EXTERNA
- CÂMARA REVESTIDA EM VERMICULITE
- TRONCOS DA LENHA ATÉ 60 CM
- VOLUME DE AQUECIMENTO 250 m³
- SISTEMA VIDRO LIMPO
- PORTA COM VIDRO SERIGRAFADO
- TRIPLA COMBUSTÃO



EAN 8426964247503
REF. 24750



BImSchV2



DF-80 EcoDesign

