

ROZMERY

VÝŠKA x ŠÍŘKA x HLOUBKA	625x700x566 mm
HMOTNOST BRUTTO/NETTO	131/111 kg
PŘÍKLÁDACÍ OTVOR	500x311 mm
PRŮMĚR KOUŘOVODU VÝVOD KOUŘOVODU	Ø 150-153 mm Vrchní
EXTERNÍ PŘÍVOD VZDUCHU	Ø 80 mm

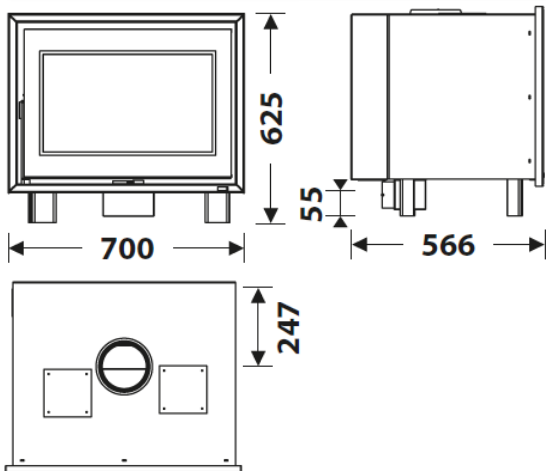







CHARAKTERISTIKA

ŽELEZNÝ ROŠT	
OCELOVÝ PLÁŠŤ KAMEN	3 mm
JMENOVITÝ VÝKON	7 KW
ÚČINNOST SPALOVÁNÍ	81 %
EMISE CO	0,10%
ŽÁRUVZDORNÁ BARVA	800°C
KERAMIZOVANÉ ŽÁRUVZDORNÉ SKLO	750°C



VLASTNOSTI

ECODESIGN 2022

-  **EXTERNÍ PŘÍVOD VZDUCHU**
-  VERMIKULITOVÁ SPALOVACÍ KOMORA
-  POTIŠTĚNÉ SKLO
-  MAXIMÁLNÍ DÉLKA POLEN 50 CM
-  VYTÁPĚCÍ SCHOPNOST 220 m³
-  SYSTÉM ČISTÉHO SKLA
-  TERCÍÁRNÍ SPALOVÁNÍ 3
-  KANALIZACE VZDUCHU
-  TANGENCIÁLNÍ VENTILÁTOR



EAN 8426964248005
REF. 24800



BImSchV2



DC-70 EcoDesign

