

MAßE

MAßE H x B x T	943x1091x465 mm
GEWICHT BRUTTO/NETTO	160/151 kg
MAßE FEUERRAUMTÜR	870x300 mm
DURCHMESSER DES ABGASSTUTZEN	Ø 150-153 mm Vertical
EXTERNE LUFTZUFUHR	Ø 80 mm

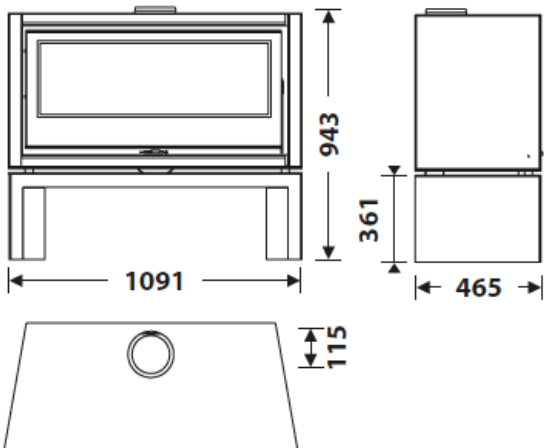







EIGENSCHAFTEN

RÜTTELROST AUS GUSSEISEN	
BLECHGEHÄUSE	5+3 mm
NENNLEISTUNG	8,9 KW
WIRKUNGSGRAD	80,8 %
CO - EMISSIONEN	0,10 %
HITZESCHUTZANSTRICH	800°C
GLASKERAMIKSCHEIBE HITZEBESTÄNDIG BIS	750°C



PRODUKT PLUS

ECODESIGN 2022

-  EXTERNE LUFTZUFUHR
-  VERMIKULIT AUSKLEIDUNG
-  SCHEITLÄNGE 80 CM
-  RAUMHEIZVERMÖGEN 240 m³
-  SCHEIBENSPÜLUNG
-  DOPPELBLECHGEHÄUSE 5 + 3 MM
-  DOPPELVERBRENNUNG
-  BEDRUCKTE GLASKERAMIK



EAN STOVE BENCH 8426964243550
REF. STOVE BENCH 24355

EAN PANORAMIC STOVE 8426964243505
REF. PANORAMIC STOVE 24350

PANORAMIC + STOVE BENCH EcoDesign



BImSchV2

