

MAßE

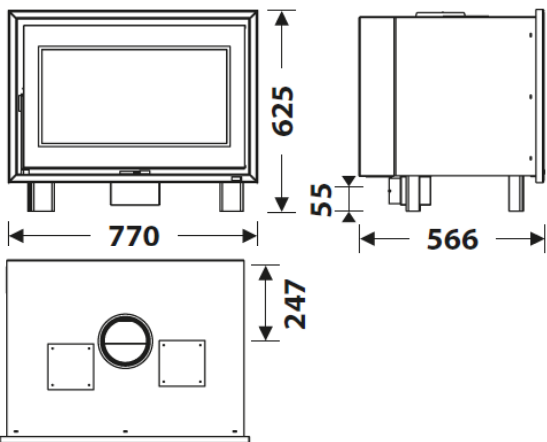







MAßE H x B x T	625x770x566 mm
GEWICHT BRUTTO/NETTO	106/96 kg
MAßE FEUERRAUMTÜR	600x300 mm
DURCHMESSER DES ABGASSTUTZEN	Ø 150-153 mm Vertical
EXTERNE LUFTZUFUHR	Ø 80 mm

EIGENSCHAFTEN

RÜTTELROST AUS GUSSEISEN	
BLECHGEHÄUSE	3 mm
NENNLEISTUNG	7 KW
WIRKUNGSGRAD	81 %
CO - EMISSIONEN	0,10%
HITZESCHUTZANSTRICH	800°C
GLASKERAMIKSCHEIBE HITZEBESTÄNDIG BIS	750°C



PRODUKT PLUS ECODESIGN 2022

-  EXTERNE LUFTZUFUHR
-  VERMIKULIT AUSKLEIDUNG
-  BEDRUCKTE GLASKERAMIK
-  SCHEITLÄNGE 60 CM
-  250 m³ RAUMHEIZVERMÖGEN
-  SCHEIBENSPÜLUNG
-  DREIFACHVERBRENNUNG
-  TANGENTIELLER VENTILATOR
-  WARMLUFT KANALISATION



EAN 8426964248500
REF. 24850



BImSchV2



DC-80 EcoDesign



DC-80

