

MABE

MABE H x B x T	647x796x595 mm
GEWICHT BRUTTO/NETTO	152/145 kg
MABE FEUERRAUMTÜR	620x286 mm
DURCHMESSER DES ABGASSTUTZEN	Ø 150-153 mm Vertical
EXTERNE LUFTZUFUHR	Ø 80 mm

EIGENSCHAFTEN

ROST AUS GUSSEISEN	
DREISEITIGE FEUERSICHT	
BLECHGEHÄUSE	5 mm
NENNLEISTUNG	7,2 KW
WIRKUNGSGRAD	77 %
CO - EMISSIONEN	0,10 %
HITZESCHUTZANSTRICH	800°C
GLASKERAMIKSCHEIBE	750°C
HITZEBESTÄNDIG BIS	

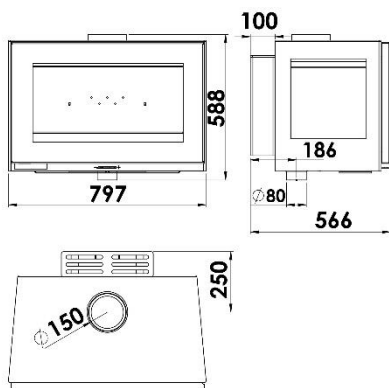

PRODUKT PLUS

ECODESIGN



EXTERNE
LUFTZUFUHR



REFRAKTÄR



SCHEITLÄNGE 60 CM



250
m³ RAUMHEIZVERMÖGEN



SCHEIBENSPÜLUNG



DREIFACHVERBRENNUNG



2-PUNKT VERSCHLUSS



EAN 8426964243055
REF. 24305



BlmSchV2



ATTITUDE WALL EcoDesign



ATTITUDE WALL DE

