

## MÉRETEK

MÉRET (M x SZ x Mé)	647x796x595 mm
BRUTTÓ/NETTÓ SÚLY	182/165 kg
AJTÓ MÉRETE	620x286 mm
FÜSTCSŐCSONK ÁTMÉRŐ	Ø 150-153 mm Függőleges
KÜLSŐ LEVEGŐ BEVEZETÉS	Ø 80 mm

## TULAJDONSÁGOK

ÖNTÖTTVAS RÁCS	
3 OLDALAS	
ACÉL TEST	5 mm
NÉVLEGES TELJESÍTMÉNY	7,2 KW
HATÁSFOK	77 %
CO	0,10 %
HÓÁLLÓ FESTÉK	800°C
ELLENÁLLÓ KERÁMIA ÜVEG	750°C

## PLUSZ TERMÉK

### ECODESIGN



KÜLSŐ LEVEGŐ  
BEVEZETÉS



FEHÉR TŰZÁLLÓ  
SZIGETELŐ LAP



TŰZIFA MÉRET: 60  
CM



BEFŰTHETŐ LÉGTÉR



TISZTA ÜVEG RENDSZER



HÁRMAS ÉGÉS



KETTÓS ZÁR

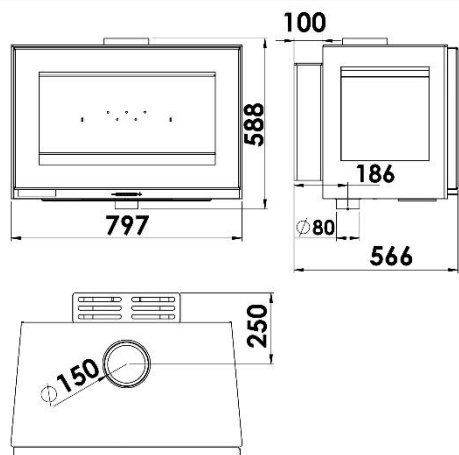

EAN 8426964243055  
REF. 24305



BlmSchV2



# ATTITUDE WALL EcoDesign



ATTITUDE WALL HU

