

MEDIDAS

DIMENSIONES AxAxF	647x796x595 mm
PESO BRUTO/NETO	152/145 kg
DIMENSIONES PUERTA	620x286 mm
SALIDA DE HUMOS	Ø 150-153 mm Vertical
ENTRADA DE AIRE EXTERIOR	Ø 80 mm

CARACTERÍSTICAS

PARRILLA DE HIERRO FUNDIDO	
TRIVISIÓN	
CUERPO EN CHAPA	5 mm
POTENCIA CALORÍFICA	7,2 KW
RENDIMIENTO	77 %
EMISIÓN DE CO	0,10 %
PINTURA ANTI-CALÓRICA RESISTENTE	800°C
CRISTAL VITROCERÁMICA RESISTENCIA	750°C

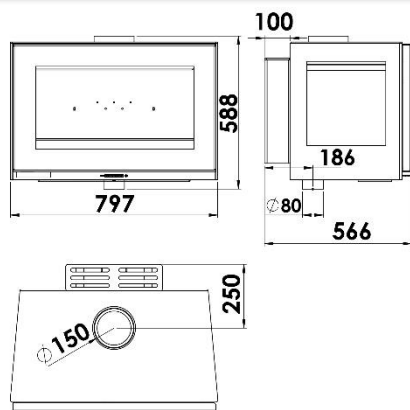

PLUS PRODUCTO

ECODESIGN



TOMA DE AIRE EXTERIOR



REFRACTARIO



RADIACION CONVECCION



TRONCOS HASTA 60 CM



VOLUMEN DE CALEFACCIÓN



TRIPLE COMBUSTION



SISTEMA CRISTAL LIMPIO



DOBLE CIERRE



EAN 8426964243055
REF. 24305



BlmSchV2



ATTITUDE WALL EcoDesign



ATTITUDE WALL ES